

Vacuum solutions for food processing and packaging

Leybold



Explore the world of freshness now

Learn more about the possibilities of vacuum: On our webpage you will not only learn about food processing and packaging, you will also find more about our customer solutions and application specific products.

Please “dive in” and experience our world of freshness.
See for yourself: www.leybold.com

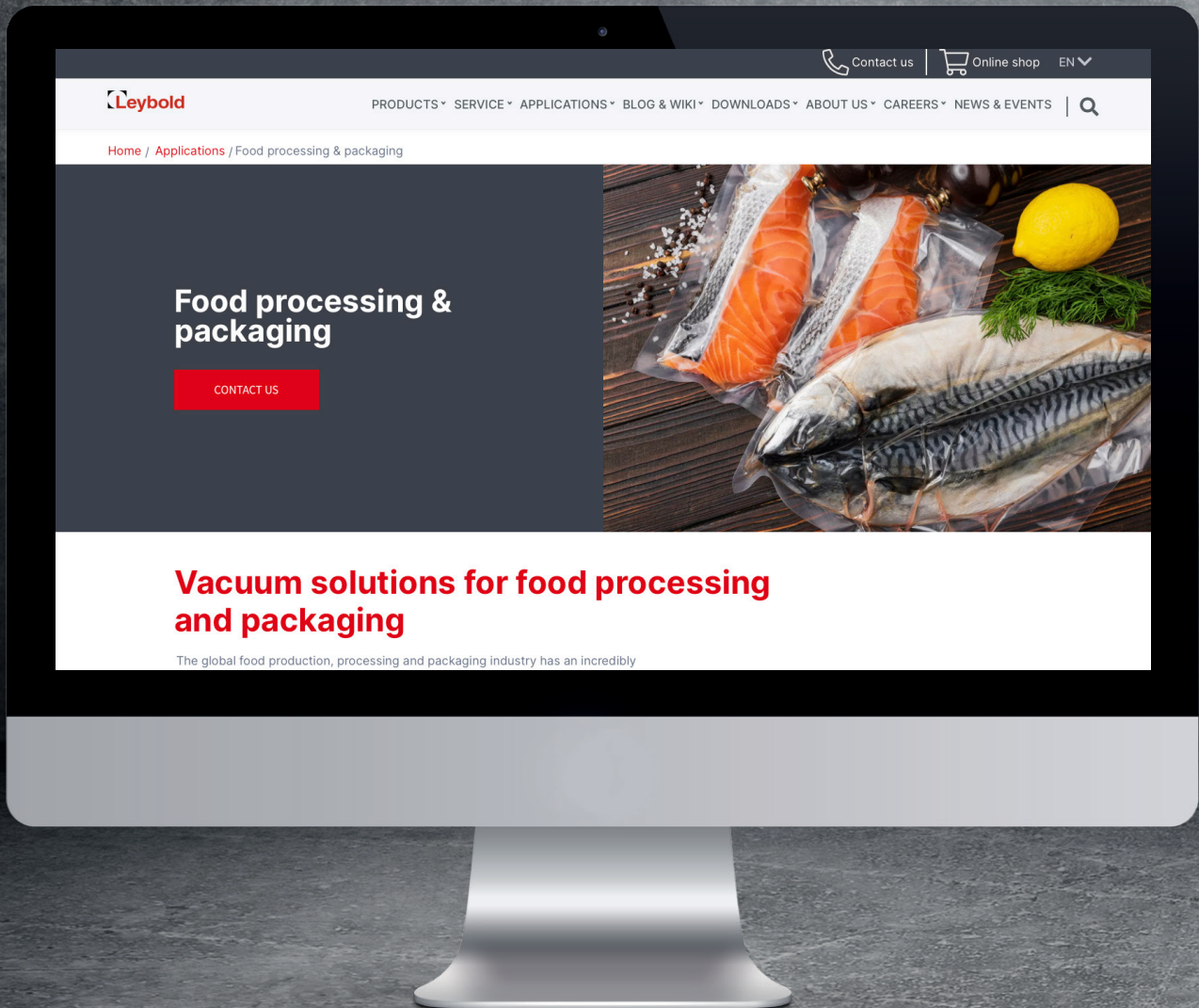

Contents

General

Application matrix food and packaging market	04
--	-----------

Products

NOVADRY dry compressing screw pump	06
DRYVAC dry compressing screw pump	08
SCREWLINE dry compressing screw pump	10
CLAWVAC dry rough vacuum claw pump	12
CLAWVAC CPi system	14
NOVADRY NDi system	14
VACUBE oil sealed screw central vacuum system	16
RUVAC WAU Roots vacuum blower	18
SOGEVAC SV B oil-sealed rotary vane pump	20
SOGEVAC oxygen pump	23
Stainless steel hygienic enclosures	24
Electrical cabinet VAContral CAB Cab	25
Liquid separator, see-through	26
Dust filter, see-through	27
Dust-filter, standard	28
LF dust filter & liquid separator	29
Vacuum pressure gauges	30
Range of LEYBONOL food-grade vacuum oils	31
Range of stainless steel fittings	32

Services	34
----------	-----------

Online Shop	36
-------------	-----------

Applications of the food & packaging market

Vacuum pumps	NOVADRY	DRWAC	SCREWLINE	CLAWVAC
Size available (m³/h)	65 - 200	200 - 800	630	65 - 1000
Cooling	Air	Water	Air or Water	Air
Washdown	Yes (with enclosure)	Yes (-r version)	No	Yes (with enclosure)
Technology	Dry screws	Dry screws	Dry screws	Dry claws
Pressure range (mbar)	1000 - 0.1	1000 - 0.005	1000 - 0.01	1000-50/140/200

Food processing				
Freeze drying	●	●	■	
Tumbling / Marinating / Mixing	■		■	■
Vacuum cooling	●	■	■	
Slaughterhouse applications	●			■
Filling / Stuffing	■			■
Vacuum cutting / grinding	■			■
Bottling	■			■
Controlled atmosphere storage	●			
Pasta processing	■		■	
Vacuum cooking / frying	■		■	■
Vacuum conveying	●			■
Vacuum microwave drying	■	■	■	
Central vacuum system for processing	●	■	■	■
Food packaging				
Belt chamber packaging machines		■		
Thermoforming / Rollstock	■	■		●
Tray sealing	■	■		
Carousel packaging		■		
Skin packaging	■	■		
MAP with O ₂	■	■		
Leak testing				●
Metal can sealing (powder milk, coffee...)				
Table top packaging machines / Clipping	■			
Central vacuum system for packaging				
Beer bottling	■	■		

- Best in class
- Recommended
- Suitable, lower capital cost with increased user maintenance

VACUBE	RUVAC WAU	SOGEVAC B	SOGEVAC B	SOGEVAC Oxygen	Application challenges			
					Gas and ambient temperature	Average operating pressure	Dust / Powder / Particles	Moisture
400 - 4800	250 - 2000	10 - 320	630 - 750	16 - 320				
Air or Water	Air	Air	Air or Water	Air				
No	Yes	Yes (with enclosure)	No	Yes (with enclosure)				
Lubricated screws	Roots	Oil sealed rotary vane	Oil sealed rotary vane	Oil sealed rotary vane				
1000 - 1	-----	1000 - 0,08	1000 - 0,08	1000 - 0,5				
	■	●	●		L	L	M	H
		●			L	H	H	H
	■	●	●		L	M	L	M
					L	H	H	H
		●			L	M	M	H
					L	H	M	H
●			●		L	M	L	H
		●	●		L	H	L	L
●		●	●		M	H	H	H
					H	M	L	H
					H	M	L	M
					H	M	M	M
■			●					
●	●		●		L	M	L	L
●	●	●	●		L	M	L	L
●	●	●	●		L	M	L	L
●	■		●		L	L	L	L
●	●	●	●		L	L	L	L
				■	L	M	L	L
		●			L	L	L	L
●		●	●		L	M	L	L
		■			L	L	L	L
■	■		●		L	L	L	L
					L	H	L	H

L = Low
M = Medium
H = High

Dry compressing screw pump

NOVADRY



NOVADRY ND 200



The **NOVADRY** sets new standards for the food packaging and processing applications.

It is the only 100% oil free and air cooled vacuum pump on the market. Its noise level is also incredibly low.

Maintenance and service requirement are reduced to the minimum.

Its design already incorporates hygienic design rules, not allowing accumulations of liquids. Full process room wash-down capability can be reached with the optional stainless enclosures.

Our solution

- Dry screw technology
- Air cooled
- Sizes 65, 100, 160 and 200 m³/h

Typical applications

- Thermoforming
- Chamber packaging
- Tray sealing
- Skin packaging
- Tumbling / mixing
- Stuffing filling

Customer benefits

- Maximum food safety (no oil leakage nor oil mist at exhaust)
- High uptime and performance
- Low total cost of ownership by most robust design
- Simple installation and operation
- Comfort of use for the operators: low and comfortable noise thanks to optimized rotor design and, integrated silencer
- Suited to handle Oxygen (> 21%) in MAP applications

Options

- Stainless steel hygienic enclosures for full wash-down capability

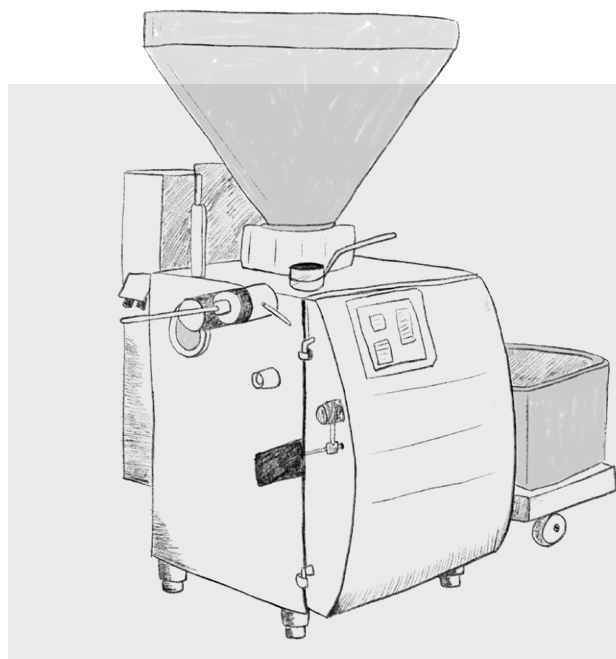

Link to the principle of operation video

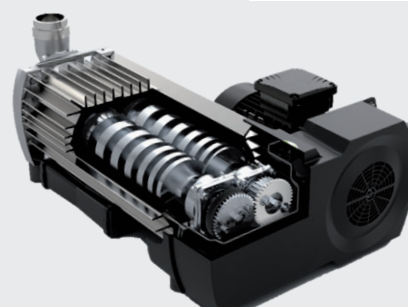

Screw drive by a pulley system - single belt for 100% clean vacuum generation

Technical data		NOVADRY			
		ND 65	ND 100	ND 160	ND 200
Nominal speed without gas ballast ¹⁾	m ³ x h ⁻¹	63	96	138	175
Ultimate pressure without gas ballast ¹⁾	mbar	0.1	0.1	0.1	0.1
Water vapor tolerance with gas ballast	mbar	60	60	60	60
Water vapor capacity with gas ballast	kg x h ⁻¹	1.9	2.9	5.2	6.9
Permissible ambient temperature	°C	0 to 40	0 to 40	0 to 40	0 to 40
Cooling		Air	Air	Air	Air
Mains voltage					
50 Hz versions	V	400 or 200, ±10%	400 or 200, ±10%	400 or 200, ±10%	400 or 200, ±10%
60 Hz versions	V	460 or 230, ±10%	460 or 230, ±10%	460 or 230, ±10%	460 or 230, ±10%
		200/380, ±10%	200/380, ±10%	200/380, ±10%	200/380, ±10%
Motor power	W	1500	2200	3000	4000
Protection class EN 60529	IP	55	55	55	55
Noise level with integrated silencer at ultimate pressure ²⁾	dB(A)	67	70	70	73
Connections					
Intake side	DN	G 2"	G 2"	G 2"	G 2"
Pressure side	DN	G 1 1/2"	G 1 1/2"	G 1 1/2"	G 1 1/2"
Weight, approx.	kg	85	95	105	115
Dimensions (W x H x D)	mm	488 x 315 x 644	488 x 315 x 736	488 x 315 x 889	488 x 315 x 889

¹⁾ To DIN 28 400 ff.

²⁾ To DIN EN ISO 2151

Ordering information	NOVADRY			
	ND 65 Part No.	ND 100 Part No.	ND 160* Part No.	ND 200* Part No.
NOVADRY dry screw pump with 3 phase motor				
400V+/-10% or 200V+/-10%, 50 Hz	111065N10	111100N10	111160N10	111200N10
460V+/-10% or 230V+/-10%, 60 Hz	111065N11	111100N11	111160N11	111200N11
380V+/-10% or 200V+/-10%, 60 Hz	111065N21	111100N21	111160N21	111200N21
Outlet adaptor G1"1/2	111005A32			
Purge upgrade kit	111005A01			
Flushing kit (purge gas required)	111005A00			
Hygienic enclosures NOVADRY	HygEn001			
Soft Starter VD/ND, ≥ 11A, 110-230 V AC	-		111005A65	
Soft Starter VD/ND, ≥ 11A, 24 V DC	-		111005A66	
Soft Starter VD/ND, ≥ 19A, 110-230 V AC	-		111005A67	
Soft Starter VD/ND, ≥ 19A, 24 V DC	-		111005A66	
Replacement timing belt 50 Hz versions	EK6528531			
Replacement timing belt 60 Hz versions	EK6528533			
Belt replacement tool kit	EK6530942			

* Soft starter mandatory

Dry compressing screw pump

DRYVAC



**DRY AND
EXTREMELY
COMPACT**

Our **DRYVAC** is a rugged, dry screws vacuum pump with excellent energy efficiency. Compactness and low noise level enable installation close to the machine resulting in shorter cycle time and lower cost of installation.

The hygienic design (DV 650 and DV 800 only) avoids accumulation of water and dirt on the surface which makes this pump perfectly suitable for installation in washdown environment and easy to clean.

Our DRYVAC DV650 and 800 can be equipped with either:

- Standard stainless steel silencer (assembled on the side) for clean applications (packaging...)
- Serviceable stainless steel silencer (cleanable internally) for the most demanding application with possible accumulation of dirt/particles

Typical applications

- Freeze drying
- Thermoforming
- Vacuum baking and cooling
- Modified Atmosphere Packaging (MAP) and skin packaging
- Vacuum cooling
- Belt chamber packaging machines

Our solution

- Dry screw technology
- Water cooled
- Driven by frequency converter
- ISO-6 certificate for clean rooms
- PFPE versions for MAP of red meat with oxygen
- Direct connection of **RUVAC** Roots blower via adapter
- Options:
 - Plug and Go device to control the purge valves, gas ballast and flushing valve according to the process
 - E-saver allowing up to 50% energy savings at low pressure

Customer benefits

- Extremely compact design and water cooling allows installation directly inside the air-conditioned process area
- High energy efficiency
- Three inlet ports available allowing flexible installation and connection to the machine
- Integrated (or remote) frequency converter for optimal process control and easy networking

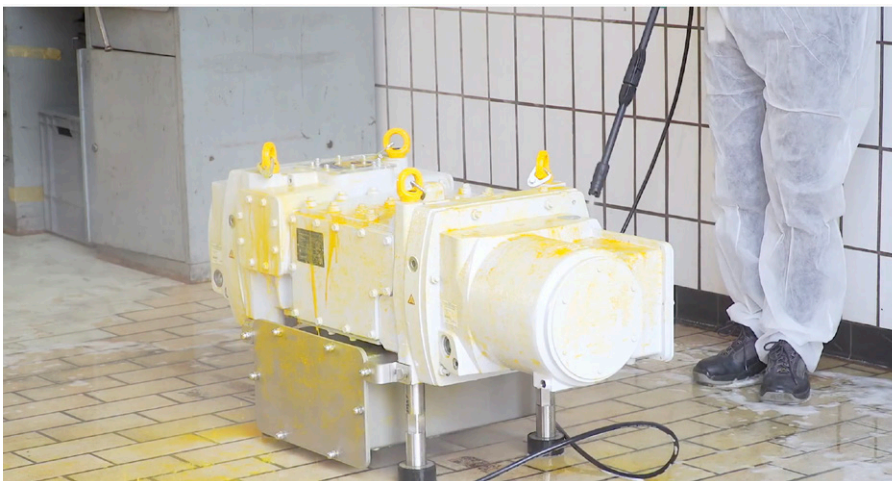

DRYVAC DV 650 FP-r designed for wash-down environment

Technical data

		DRYVAC		
		DV 300 50/60 Hz	DV 650 FP-r Hygienic 50/60 Hz	DV 800 FP-r Hygienic 50/60 Hz
Nominal speed ¹⁾	m ³ x h ⁻¹	280	650	800
Ultimate pressure ¹⁾	mbar	≤ 0.01	≤ 0.005	
Maximum permissible water vapor capacity	kg x h ⁻¹	5	25	30
Cooling	°C	Water		
Motor power	kW	7.5	15	22
Protection class EN 60529	IP	54		
Lubricant filling	l	1.0	1.2	
Noise level ²⁾	dB(A)	65	70	73
Connections				
Intake side	DN	63 ISO-K	100 ISO-K	
Pressure side	DN	40 ISO-K	63 ISO-K	
Weight, approx.	kg	370	560	
Dimensions (W x H x D)	mm	1115 x 612 x 478	1211 x 450 x 400	

¹⁾ To DIN 28 400 ff.²⁾ Operated at the ultimate pressure without gas ballast, free-field measurement at a distance of 1 m (3.5 ft)**Ordering information**

	DRYVAC		
	DV 300 Part No.	DV 650 FP-r Hygienic Part No.	DV 800 FP-r Hygienic Part No.
With double purge - with LVO 210 With gas ballast and blow-off valve	112030V15	-	-
With remote frequency converter, F&P version with epoxy painting with LVO 210	-	112065FP01-1	112080FP01-1
With remote frequency converter, F&P version with epoxy painting with LVO 210 with cleanable silencer in stainless steel	-	112065FP02-1	112080FP02-1
With remote frequency converter, F&P version with epoxy painting with LVO 410 - PFPE	-	112065FP21-1	112080FP21-1
With remote frequency converter, F&P version with epoxy painting with LVO 410 - PFPE with cleanable silencer in stainless steel	-	112065FP22-1	112080FP22-1
Inlet threaded adapter 3" ¹⁾	-	112005418	
Inlet threaded adapter 4" ¹⁾	-	112005A19	
Stainless steel inlet plate DV 650/800 FP	-	112005A51	
Exhaust silencer in stainless steel	115005A21	112005A50	
E-Saver device (only for LVO 210 versions) ²⁾	-	112005A60	

¹⁾ For assembly on side inlet ports²⁾ Not for installation in wash-down area

**Have a look at our dry compressing,
robust vacuum pumps DRYVAC
DV 650. We show you a robustness test
by the ingressing of 10 liter of water:**

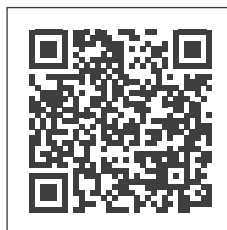

Dry compressing screw pump

SCREWLINE



Our **SCREWLINE** is an extremely robust dry screw pump for food processing applications with on-site cleanability of pump chamber and screw rotors by the user.

Our solution

- Dry screw technology
- Cantilevered design
- Air cooled
- Pumping speed 630 m³/h
- Ultimate pressure $\leq 1 \times 10^{-2}$ mbar
- Monitoring system
- Direct connection of **RUVAC** Roots pumps via adapter

Typical applications

- Freeze drying
- Tumbling
- Vacuum conveying
- Vacuum cooling

Customer benefits

- Designed for demanding processes
- High uptime
- Low total cost of ownership
- Easy to disassemble pump chamber for rapid cleaning

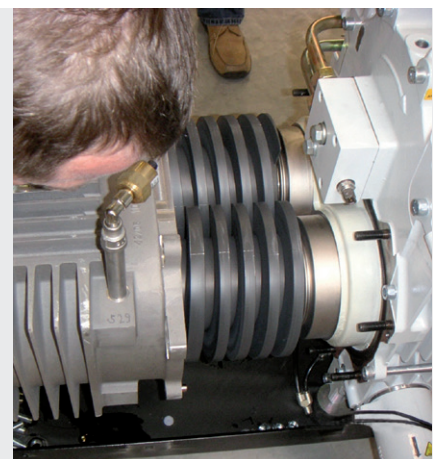
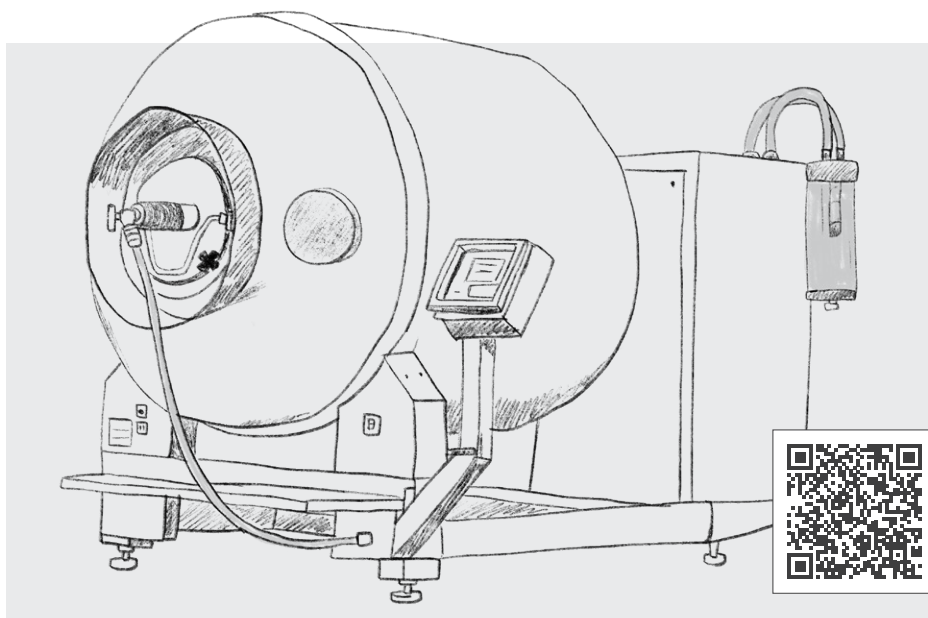

SCREWLINE pumps enable simple disassembly of the pump chamber for on-site cleaning by the customer

Technical data

		SCREWLINE
		SP 630 50/60 Hz
Nominal speed ¹⁾	m ³ x h ⁻¹	630
Ultimate pressure ¹⁾	mbar	≤ 0.01
Maximum permissible water vapor capacity	kg x h ⁻¹	14
Cooling	°C	Air
Motor power	kW	15
Protection class EN 60529	IP	55
Lubricant filling	l	13
Noise level ²⁾	dB(A)	73
Connections		
Intake side	DN	63 ISO-K
Pressure side	DN	100 ISO-K
Weight, approx.	kg	530
Dimensions (W x H x D)	mm	1630 x 880 x 660

¹⁾ To DIN 28 400 ff.

²⁾ Operated at the ultimate pressure without gas ballast, free-field measurement at a distance of 1 m (3.5 ft)

Ordering information

		SCREWLINE
		SP 630 Part No.
With manual gas ballast and SPGuard 400V, 50Hz / 200V, 50Hz / 460V, 60Hz / 210V, 60Hz		- -
With manual gas ballast and SPGuard 190V-210V / 380V-420V, 50Hz 190V-210V / 380V-420V, ±5%, 60Hz		117007 117008
SCREWLINE Oxygen version with electromagnetic gas ballast and SPGuard 190V-210V / 380V-420V, ±5%, 50Hz 190V-210V / 380V-420V, ±5%, 60Hz		117039 117040
Exhaust silencer		119001

Dry rough vacuum pump

CLAWVAC

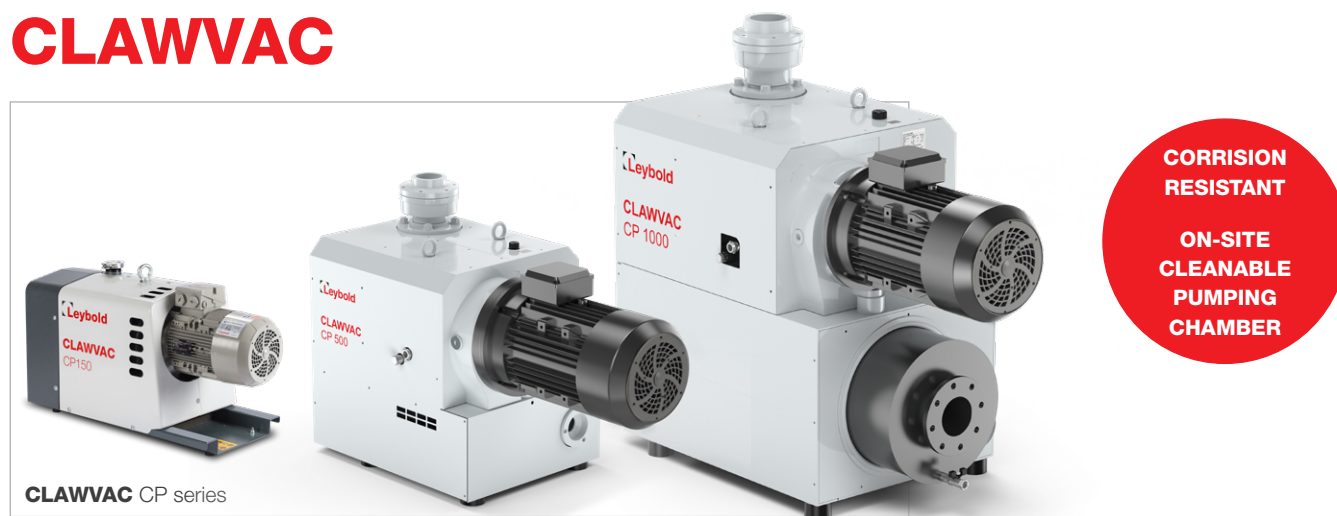

CLAWVAC CP series

The **CLAWVAC** operates smoothly with a pair of wearfree rotating claw rotors. The **CLAWVAC** differentiates itself from conventional claw pumps mainly through its material selection.

Stainless steel rotors as well as the corrosion-resistant coated vacuum chamber deliver stable operation even under very harsh process conditions.

The **CLAWVAC** offers great advantages for a wide range of rough vacuum applications.

The pump design offers extreme robustness, especially for challenging applications, which include handling of particle or vapor contaminated gases.

Our solution

- Dry claw technology
- Air cooled
- Pumping speed 65, 150, 300, 500 and 1000 m³/h
- Compact design, small space requirements
- Extremely efficient air cooling, low heat emission
- Low total cost of ownership

Typical applications

Food processing

- Bottling
- Dairy products (e.g. milking)
- Vacuum conveying (e.g. slaughterhouse)
- Beverage production
- Tumbling / Marinating
- Mixing / Cutting

Food packaging

- Thermoforming of foil containers
- Tray sealing
- Modified Atmosphere Packaging of red meat with O₂ (with Oxygen versions only)

Customer benefits

- Oil free generation (no oil migration into process, no oil contamination to the environment) guarantees maximal food safety
- Comfort of use for the operator thanks to low noise level
- Low maintenance requirements and low operating cost
- Simple and complete on-site cleaning of all surfaces in contact with process media

Options

- Stainless steel hygienic enclosures for full wash-down capability

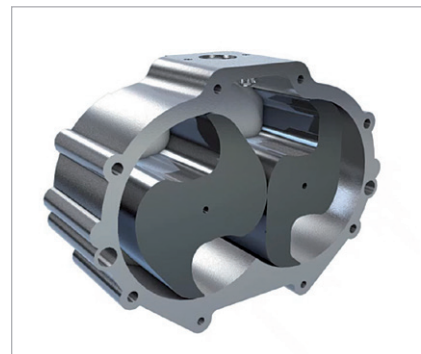

Stainless steel claws and corrosion resistant pumping chamber

Technical data

		CLAWVAC				
		CP 65	CP 150	CP 300	CP 500	CP 1000
Pumping speed ¹⁾						
50 Hz	m ³ x h ⁻¹	65	150	300	500	1000
60 Hz	m ³ x h ⁻¹	79	184	347	600	1140
Ultimate pressure	mbar	50		140	200	
Continuous operation range	mbar	50-1000		140-1000	200 - 1000	
Permissible ambient temperature range	°C	0 - 40				
Connections						
Inlet		G 1 1/4" or NPT		G 2" or NPT	G3"	DN100 PN6
Outlet		G 1 1/4" or NPT		G 1 1/4" or NPT	G2 1/2"	DN100 PN10
Motor power						
50 Hz	kW	1.8	3.7	6.2	9.2	18.5
60 Hz	kW	2.2	4.4	7.5	11	22
Operation range	Hz	20 - 60				
Noise level (50 / 60 Hz)	dB(A)	66 / 77	75 / 80	77 / 84	80/82	82/85
Weight, approx.	kg	120	160	252	313	615
Motor protection class	IP	55				

¹⁾ To DIN 28 400 ff.

Ordering information

	CLAWVAC				
	CP 65 Part No.	CP 150 Part No.	CP 300 Part No.	CP 500 Part No.	CP 1000 Part No.
Dry vacuum pump with 3 phase motor					
230 V, 50 Hz	178065V01	178150V01	178300V01		
380 V, 60 Hz	178065V02	178150V02	178300V02	10790500V03	10791000V03
400 V, 50 Hz	178065V03	178150V03	178300V03	10790500V02	10791000V02
575 V, 60 Hz	178065V04	178150V04	178300V04		
200 V, 60 Hz	178065V05	178150V05	178300V05		
230/460 V, 60 Hz (460 V, 60 Hz only for CP 500 / 1000)	178065V07	178150V07	178300V07	10790500V04	10791000V04
200 V, 50 Hz	178065V08	178150V08	178300V08		
CLAWVAC oxygen versions					
380 V, 60 Hz 3Ph O ₂ for high oxygen	178065V12	178150V12	178300V12		
400 V, 60 Hz 3Ph O ₂ for high oxygen	178065V13	178150V13	178300V13		
575 V, 60 Hz 3Ph O ₂ for high oxygen	178065V14	178150V14	178300V14		
200 V, 60 Hz 3Ph O ₂ for high oxygen	178065V15	178150V15	178300V15		
230/460 V, 60 Hz 3Ph O ₂ for high oxygen	178065V17	178150V17	178300V17		
CLAWVAC accessories					
Inlet filter & elbow G3"				10790500A00	
Outlet silencer G2-1/2"				10790500A01	
Inlet filter & elbow DN100					10791000A00
Outlet silencer DN100					10791000A01
Flushing kit	111005A00	111005A00	111005A00		
Hygienic enclosures CLAWVAC	HygEn006		HygEn007		

Dry rough vacuum pump

CLAWVAC and NOVADRY systems - CPI / NDi



CPI and NDi are variable speed, dry vacuum systems using multiple pumps: up to three **NOVADRY** screw pumps (NDi) or four **CLAWVAC** claw pumps (CPI). The smart control allows operation at the selected target pressure to not waste any performance or energy. All pump data is available anytime – from anywhere and intelligent software functions like maintenance and service alerts or the set up of different user profiles guarantee best operation performance.

Our solution

- Dry air-cooled systems- Strong internal chassis with forklifting facilities for easy handling
- Easy accessibility of the pumps for service
- Full monitoring and control facilities

Customers benefits

- Dry vacuum: central vacuum systems without any risk of oil contamination
- “Plug & pump”: an easy-to-install package to replace old technologies
- Ready for harsh processes providing better uptime
- Economical to run: the on-board controller will enable to optimize pumping speed to the process needs and save energy
- Low total cost of ownership

Typical applications

- Conveying of food and waste products (CPI)
- Pick and place (CPI)
- Holding, lifting (CPI)
- CVS for applications requiring pressure above 150 mbar (CPI)
- Thermoforming (NDi, CPI)
- CVS for applications with 10 - 100 mbar working pressure (NDi)
- Modified Atmosphere Packaging including with high oxygen concentration (NDi)

Technical data		CLAWVAC system		
		CPI 600	CPI 900	CPI 1200
Pumping speed	m ³ x h ⁻¹	44 - 604	44 - 874	44 - 1144
Ultimate pressure	mbar	150		
Noise level ¹⁾	dB (A)	74	73	
Motor power	kW	1.2 - 14	1.2 - 20.5	1.2 - 27
Weight	kg	1096	1521	1821
Dimensions (L x W x H)	mm	1420 x 984 x 1980	1420 x 1639 x 1980	
Connections Inlet / Outlet		DN 80	DN 100	

¹⁾ According to DIN EN ISO 2151

Ordering information*		CLAWVAC system		
		CPI 600	CPI 900	CPI 1200
CLAWVAC 400 V, 50 Hz, 3 phase motor	m ³ x h ⁻¹	178600V01	178900V01	1781200V01

* For detailed information on our full scope of CLAWVAC pumps and motor versions, please refer to our general catalog. Visit our webshop www.leyboldproducts.com. Please contact us for technical details on the entire CLAWVAC Systems range.

Technical data		NOVADRY NDi system	
		ND 400i	ND 600i
Maximum pumping speed (w/o gas ballast)	m ³ /h	400	600
Ultimate pressure w/o gas ballast	mbar	5	
Max. permissible outlet pressure (rel. to ambient)	mbar	200	
Max. permissible inlet pressure	mbar	1200	
Water vapor tolerance with gas ballast	mbar	60	
Water vapor capacity with gas ballast	kg/h	13,8	20,7
Permissible ambient temperature	°C	0 to +40	
Nominal motor power 50Hz / 60Hz	kW	9	13
Weight, approx.	kg	692	997
Dimensions (L x W H)	mm	1410 x 925 x 1503 x 880	1410 x 925 x 1979
Inlet / outlet connection		DN80 / DN80	

Ordering information		NOVADRY NDi system	
		ND 400i Part No.	ND 600i Part No.
50 Hz, 200/400V		111400NDi01	111600NDi01
60 Hz, 230/460V		111400NDi02	111600NDi02
60 Hz, 200/380V		111400NDi03	111600NDi03

Oil-sealed screw central vacuum system

VACUBE



The **VACUBE** range is a new generation of intelligent, single-stage, oil-sealed screw vacuum pumps with variable speed drive (VSD) technology.

VACUBE generates vacuum on demand. The pump is controlled and maintained by an internal controller. The system offers superior performance for a wide range of rough vacuum applications.

Four models are available. Next to the standard model, the „iH“ model should be used for vapour handling. the „iC“ model is ideal for high cycling applications. „iHC“ is there to cover humid cycling applications.

Our solution

- Plug and Go system set up
- Highly efficient oil-sealed rotary screw technology
- Pumping speed 420 to 4.972 m³/h
- Optimal working pressure range: 5-400 for VQ and 5-1000 for VQ²
- Integrated frequency inverter for load depending speed control
- Controller with intuitive menu navigation for configuration and control
- Air- or water-cooled versions
- Small footprint
- Programmable operation modes
- Long maintenance intervals
- Assembly of Roots blowers Roots WS 3001, WH(U) 2500 and WH 7000 possible on iR versions

Typical applications

- Central vacuum systems for packaging and processing
- Meat packaging under modified atmosphere (no O₂)
- Chamber packaging
- Canning

Customer benefits

- Sustainable power saving due to on-demand vacuum generation
- Low total cost of ownership

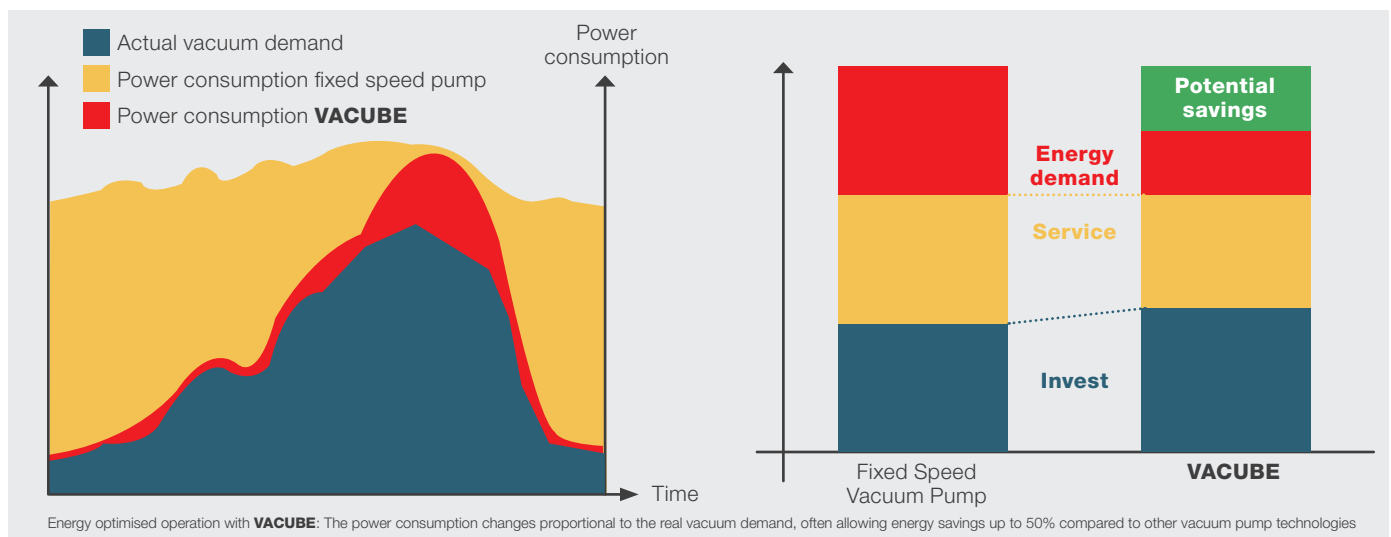

Technical data

		VACUBE i - iH - iR			
		VQ 400	VQ 550	VQ 700	VQ 800
Pumping speed, max. eff. ¹⁾	m ³ x h ⁻¹	420	530	700	790
Motorshaft power	kW	5.5	7.5	11	15
Noise level	dB(A)	51 - 65		51 - 73	51 - 76
Weight	kg	500		510	520
Supply voltages*	Hz	380 - 460 V, 3 phase, 50/60 Hz			

		VQ² 1350	VQ² 1600	VQ² 1800
		Pumping speed, max. eff. ¹⁾	m ³ x h ⁻¹	1370
Motorshaft power	kW	22	30	37
Noise level	dB(A)	76	78	78
Weight	kg	1210	1220	1230
Supply voltages*	Hz	380 - 460 V, 3 phase, 50/60 Hz		

		VQ 3600	VQ 4200	VQ 4800
		Pumping speed, max. eff. ¹⁾	m ³ x h ⁻¹	3739
Motorshaft power	kW	55	75	90
Noise level	dB(A)	70 - 83	70 - 84	70 - 85
Weight	kg	3945	3980	4000
Supply voltages*	Hz	380 - 460 V, 3 phase, 50/60 Hz		

¹⁾ To DIN 28 400 ff.

* Other voltages available on request

Ordering information

	VACUBE i - iH - iR		
	i Models Part No.	iH Models Part No.	iR Models Part No.
VACUBE VQ 400	177040V01	177040V10	
VACUBE VQ 550	177055V01	177055V10	
VACUBE VQ 700	177070V01	177070V10	
VACUBE VQ 800	177080V01	177080V10	
VACUBE VQ ² 1350	10771350V05	10771350V15	10771350V25
VACUBE VQ ² 1600	10771600V05	10771600V15	
VACUBE VQ ² 1800	10771800V05	10771800V15	10771800V25
VACUBE VQ 3600	177360V01QD	177360V10QD	
VACUBE VQ 4200	177420V01QD	177420V10QD	
VACUBE VQ 4800	177480V01QD	177480V10QD	
LEYBONOL vacuum oil LVO 320, 20 liter	L320 20	L320 20	

Water-cooled versions and other variants available, please contact us.

Roots vacuum blower

RUVAC WAU



Roots blowers, also called boosters are contactless dry impellers pumps.

In combination with forevacuum pumps, the use of RUVAC Roots blowers features:

- increased pumping speed
- improved ultimate pressure
- shortened cycle times

Our solution

- Air-cooled line WAU with four blower sizes
- Reliable and trouble-free operation
- Easy installation, direct coupling without a support frame for SOGEVAC SV 100 or larger
- Available with special motors if required
- Integrated pressure equalization line for protection against overloading at high pressures
- Conversion from vertical to horizontal flow
- Maintenance-friendly
- Mineral oil LVO 100 is used as standard. The required lubricant filling is included with the delivery
- Gasket in the intake flange with dirt sieve

Typical applications

- Large capacity chamber packaging machines
- Vacuum cooling of fruits and vegetables
- Freeze drying

Customer benefits

- Shorter cycle time and/or higher production output
- Low total cost of ownership

Technical data

		RUVAC			
		WAU 251	WAU 501	WAU 1001	WAU 2001
Nominal speed ¹⁾ at 50 Hz at 60 Hz	m ³ x h ⁻¹ m ³ x h ⁻¹ (cfm)	253 304 (179)	505 607 (357)	1000 1200 (707)	2050 2462 (1449)
Ultimate pressure for combination with fore vacuum pump	mbar (Torr)	6.7 x 10 ⁻² (5 x 10 ⁻²)			
Motor power	kW (hp)	1.1 (1.5)	2.2 (3.0)	4.0 (5.4)	7.5 (10.0)
Noise level	dB(A)	< 64	< 67	< 75	< 80
Oil capacity	l (qt)	0.7 (0.74)	1.2 (1.3)	1.8 (1.9)	1.8 (1.9)
Connecting flanges	DN	63 ISO-K		100 ISO-K	160 ISO-K

¹⁾ To DIN 28 400 ff.

Ordering information

	RUVAC			
	WAU 251 Part No.	WAU 501 Part No.	WAU 1001 Part No.	WAU 2001 Part No.
RUVAC WAU ... 3 phase motor 200-240 V / 380-400 V, 50 Hz 200-240 V / 380-480 V, 60 Hz	117 21	117 31	117 41	117 51

Oil-sealed rotary vane vacuum pump

SOGEVAC



SOGEVAC are proven oil sealed rotary vane pumps. This technology has been used by the food industry since decades and is today recognized as a standard.

SOGEVAC are compatible with food grade NSF H1 oil - available on request.

Our solution

- High pumping speed / footprint ratio by compact design
- Maximum tightness and low complexity thanks to integrated functions and no external pipes
- Lowest noise level on the market
- Wide range of motors available for all pump sizes
- Complete pump range from 10 m³/h to 750 m³/h
- Based on proven **SOGEVAC** design with manual gas ballast and oil filter
- Air or water-cooling options available on SV 320 B and bigger
- Adaptors for direct mounting of Roots blowers on SV 100 B and bigger

Typical applications

- Thermoformers / Rollstock machines
- Chamber packaging machines
- Modified Atmosphere Packaging (except with O₂)
- Rotary chamber packaging
- Blenders
- Stuffers
- Vacuum cutters
- Freeze drying
- Vacuum cooling
- Central vacuum systems

Customer benefits

- Low cost of ownership by easy maintenance and minimized after sales costs

Options

- Stainless steel hygienic enclosures for full wash-down capability (up to SV 320 B)

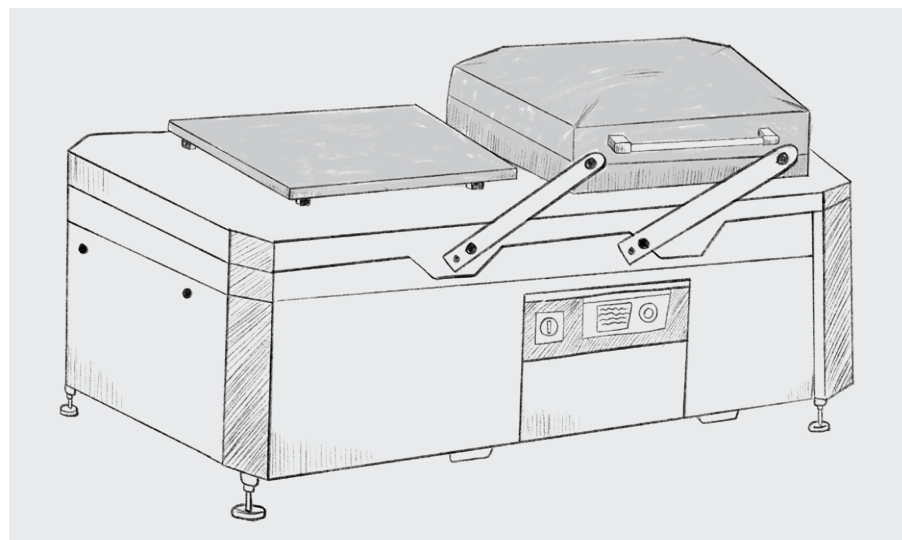

Technical data (50Hz)		SOGEVAC			
		SV 10 B	SV 16 B	SV 25 B	SV 40 B
Nominal speed ¹⁾	m ³ x h ⁻¹ (cfm)	11 (6.5)	16.0 (9.4)	26.0 (15.3)	44.0 (25.9)
Pumping speed ¹⁾	m ³ x h ⁻¹ (cfm)	9.5 (5.6)	15.0 (8.8)	22.5 (13.3)	38.5 (22.7)
Ultimate partial pressure without gas ballast ¹⁾	mbar (Torr)	≤ 1.5 (≤ 1.1)	≤ 1.0 (≤ 0.8)	≤ 0.5 (≤ 0.4)	
Ultimate total pressure without gas ballast ¹⁾	mbar (Torr)	≤ 2.5 (≤ 1.9)	≤ 2.0 (≤ 1.5)	≤ 0.8 (≤ 0.6)	≤ 1.5 (≤ 1.1)
Maximum permissible water vapor capacity	kg x h ⁻¹ (qt/hr)	0.02 (0.02)		0.085 (0.09)	0.76 (0.81)
Motor power	kW (hp)	0.55 (0.75)	0.55 (0.75)	0.9 (1.2)	1.1 (1.5)
Noise level ²⁾	dB(A)	60	60	64	58
Oil capacity	l (qt)	0.5 (0.53)			1.0 (1.05)
Connections ³⁾					
Intake side ⁴⁾	G or NPT	3/4" + 1/2"		3/4" + 1/2"	1 1/4"
Pressure side	G or NPT	-		3/4"	1 1/4"
		SV 65 B	SV 100 B	SV 220 B	SV 320 B
Nominal speed ¹⁾	m ³ x h ⁻¹ (cfm)	59.0 (34.8)	97.5 (57.4)	180 (106)	330 (194)
Pumping speed ¹⁾	m ³ x h ⁻¹ (cfm)	54.0 (31.8)	87.5 (51.5)	170 (100)	284 (168)
Ultimate partial pressure without gas ballast ¹⁾	mbar (Torr)	≤ 0.5 (≤ 0.4)		≤ 0.08 (≤ 0.06)	
Ultimate total pressure without gas ballast ¹⁾	mbar (Torr)	≤ 1.5 (≤ 1.1)		≤ 0.7 (≤ 0.5)	
Maximum permissible water vapor capacity	kg x h ⁻¹ (qt/hr)	1.0 (1.1)	1.6 (1.7)	3.4 (3.6)	1.3 (1.4)
Motor power	kW (hp)	1.5 (2.0)	2.2 (3.0)	4.0 (5.4)	7.5 (10)
Noise level ²⁾	dB(A)	60	61	69	70
Oil capacity	l (qt)	2.0 (2.1)		9.0 (9.5)	11.5 (12.2)
Connections ³⁾					
Intake side ⁴⁾	G or NPT	1 1/4"		2"	
Pressure side	G or NPT	1 1/4"		2"	
		SV 630 B	SV 750 B	* Please refer to our general catalogue for the 60 Hz versions specifications	
Nominal speed ¹⁾	m ³ x h ⁻¹ (cfm)	700 (412)	840 (494)		
Pumping speed ¹⁾	m ³ x h ⁻¹ (cfm)	640 (377)	755 (444)		
Ultimate partial pressure without gas ballast ¹⁾	mbar (Torr)	≤ 0.08 (≤ 0.06)			
Ultimate total pressure without gas ballast ¹⁾	mbar (Torr)	≤ 0.7 (≤ 0.5)			
Maximum permissible water vapor capacity	kg x h ⁻¹ (qt/hr)	17.0 (18.0)	24.0 (25.4)		
Motor power	kW (hp)	15.0 (20.1)	18.5 (24.8)		
Noise level ²⁾	dB(A)	72	75		
Oil capacity	l (qt)	23.0 (24.3)			
Connections ³⁾					
Intake side ⁴⁾	G or NPT	100 PN / 100 ISO-K			
Pressure side	G or NPT	Option			

¹⁾ To DIN 28 400 and following numbers

²⁾ Operated at the ultimate pressure without gas ballast, free-field measurement at a distance of 1 m (3.5 ft)

³⁾ 1/2" adapter supplied. Basic port is 3/4"

⁴⁾ Single-phase motors do not have plugs, cords or ON/OFF switches

Oil-sealed rotary vane vacuum pump

Ordering information	SV 10 B Part No.	SV 16 B Part No.	SV 25 B Part No.	SV 40 B Part No.	SV 65 B Part No.
Three-phase world motor	960 100	960 160	960 251	960 324	960 424
Three-phase world motor 230 V / 400 V, 50 + 60 Hz / 460 V, 60 Hz	-	-	-	960 307	960 407
Single-phase world motor 230 V, 50/60 Hz; G	960 105	960 165	960 256	-	-
230 V, 50/60 Hz; NPT	-	-	960 257	-	-
110 - 120 V, 60 Hz	960 110	960 170	-	-	-
Hygienic enclosures SOGEVAC	-	-	-	-	HygEn002

	SV 100 B Part No.	SV 220 B Part No.	SV 320 B Part No.	SV 630 B Part No.	SV 750 B Part No.
Three-phase Europe motor 230 V / 400 V, 50 Hz and 460 V, 60 Hz	960 507	960602V	960722V	960 863	960 875
Three-phase USA motor ¹⁾ 230 V / 460 V, 60 Hz and 400 V, 50 Hz UL/CSA with terminal board	960 514	10330220V01	960732V1706	960 865	-
Three-phase world motor 230 V / 400 V, 50 + 60 Hz / 460 V, 60 Hz	960 524	960617V	960732V	960 863 V3021	960 875 V2091
230 V, 50/60 Hz; NPT	-	-	960 257	-	-
110 - 120 V, 60 Hz	960 110	960 170	-	-	-
Hygienic enclosures SOGEVAC	HygEn002	HygEn003	HygEn004	-	-

¹⁾ Pumps with USA motors have NPT inlet and outlet flanges

Oil for SOGEVAC pumps

LEYBONOL Oils	SV 10 B SV 16 B	SV 25 B	SV 40 B SV 65 B SV 100 B	SV 220 B SV 320 B	SV 630 B SV 750 B(F)	SV Oxygen version
LVO 120 (Standard Mineral Oil)	■	■				
LVO 130 (Standard Mineral Oil)			■	■		
LVO 140 (Food Grade Oil)	●	●				
LVO 150 (Food Grade Oil)			●	●	●	
LVO 400 (PFPE Oil)						■

■ Standard ● Possible, please contact Leybold

The table only lists general applications. Your specific requirements might be subject to deeper analysis.

For further questions, please contact our technical sales support. **For information on oil specifications please refer to our general catalogue.**

SOGEVAC SV oxygen



SOGEVAC SV 100 B

As soon as oxygen is pumped at concentrations exceeding 21% (atmospheric air) the **SOGEVAC** pump needs to be prepared especially for such operation. This is typically the case in red meat Modified Atmosphere Packaging processes (MAP).

Our solution

- **SOGEVAC Oxygen** version pumps are available in the following sizes: SV 25 D, SV 65 B, SV 100 B, SV 320 B
- Hydrocarbon-free pump parts and inert PFPE oil filling for use in oxygen applications, respective when gas mixtures are pumped with O₂ concentrations exceeding 21%
- Air or water cooled
- Available in many different variants, motor voltages, ports etc.

Typical applications

- MAP (Modified Atmosphere Packaging) or red meat and tuna

Customer benefits

- Maximal safety level related to oxygen use
- Low cost of ownership thanks to lifetime of PFPE oil
- Over 10 % cycle time reduction vs. competitors' pumps on many models

Safety Precautions

As standard, the pumps are equipped with FPM (FKM) seals and an oil filter bypass. Before assembly, all parts are degreased and the pumps are tested with PFPE lubricant. Thereafter the pumps are emptied and delivered without PFPE lubricant. The pumps are supplied with special Operating Instructions (GA) and Spare Parts List (ET).

Pumps	Part No.	Ultimate pressure mbar (Torr)	
		without gas ballast	with gas ballast
SV 25 D	960211V2016 960215V2016	1.0 (0.75)	1.5 (1.13)
SV 65 B	960401V2016 960412V2016	1.0 (0.75)	2.5 (1.88)
SV 100 B	960505V2016 960512V2016	1.0 (0.75)	2.5 (1.88)
SV 320 B	960732V2016	0.5 (0.38)	1.5 (1.13)

Accessories

Stainless steel hygienic enclosures



Hygienic enclosure

Our range of stainless steel hygienic enclosures allows a perfect protection of your vacuum pump against daily wash-down processes typically encountered in the food industry. They have been designed according hygienic construction rules (for instance with slopped upper metal sheet), to avoid water retention points allowing to achieve a high level of food safety.

Our solution

- Six housings to host pumps of different technologies and sizes of 65 to 650 m³/h
- Each enclosure has been designed specifically for a given pump model and tested to ensure proper cooling
- Delivered as a kit ensuring small footprint during transportation and storage
- Made of stainless steel 316L

Customer benefits

- Quick and easy to assemble according to Do it Yourself principle
- Possibility to install the pump as close as possible to the process (packaging machine, tumbler, stuffer, etc.) allowing better machine performance and energy savings
- No long and expensive stainless steel pipes required anymore
- Perfectly cooled pump providing optimal functionality

Hygienic enclosures		Ordering information		Technical data	
Range of pumps	Model	Part No. vacuum pump	Part No. enclosure	Maximum ambient temperature	Dimensions W x H x D (mm)
NOVADRY	ND 65	1111065N10 - ... -1111065N26	HygEn001	25 °C	1130 x 660 x 530
	ND 100	1111100N10 - ... -1111100N26		15 °C	
ND 160	1111160N10 - ... -1111160N26	960 407 FP 960 507 FP 960 407 960 507		15 °C	1130 x 660 x 530
ND 200	1111200N10 - ... -1111200N26				
SOGEVAC	SV 70 FP	960 407 FP	HygEn002	15 °C	1130 x 660 x 530
	SV 105 FP	960 507 FP			
	SV 65 B	960 407			
SOGEVAC	SV 100 B	960 507	HygEn003	25 °C	1400 x 730 x 796
	SV 160 FP/B	960 597 FP, 960 582 V			
	SV 200 FP/B	109 27 FP, 109 27			
SOGEVAC	SV 220 FP/B	960 617 FP, 960 602 V	HygEn004	25 °C	1400 x 730 x 796
	SV 300 FP/B	960 702 FP, 960 702			
DRYVAC	SV 320 FP	960 722 FP	HygEn005	25 °C	1400 x 730 x 588
	DV 450	112045V15-1, 112045V20-1			
CLAWVAC	DV 650	112065FP18-1, 112065FP28-1	HygEn006	15 °C	1400 x 730 x 798
	CP 65	178065V01 - ... -178065V10			
	CP 150	178150V01 - ... -178150V10			
	CP 300	178300V01 - ... -178300V10	HygEn007		1400 x 730 x 996



Assembly principle video

To connect the outlet from the pump, an exhaust adapter is included.
For inlet connection, our range of stainless steel fittings can be used (see pages 32-33).

Electrical cabinet

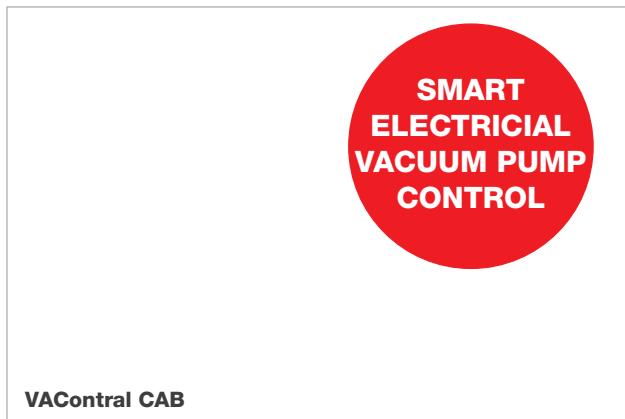

VAContral CAB is a complete solution for the electrical control of vacuum pumps, providing all necessary electrical components to be fully functional. The new smart **VAContral CAB** electrical cabinet system is instantly ready to perform. Connecting **VAContral CAB** to the power supply, vacuum pump motor(s) and included process pressure sensor installs the hardware. The pressure set point and software can easily be set via the integrated controller.

VAContral CAB is suitable for controlling NOVADRY, CLAWVAC, SCREWLINE and SOGEVAC pumps.

Our solution

- Electrical cabinet for the control of vacuum pumps
- Version for single vacuum pump control (VAContral CAB S) or multi-pump solution (VAContral CAB M)
- Integrated Variable Speed Drive for load depending speed control
- Sustainable power saving due to on-demand vacuum generation
- Controller with intuitive menu navigation for configuration and control
- Programmable operation modes
- Plug and Go system set-up

Customer benefits

- The integrated pressure setpoint control and variable-speed drives immediately offer significant energy savings
- The intelligent control of the vacuum pump(s) guarantees an optimal process pressure
- The VAContral CAB software can contribute to an increase in the stability of the production process
- VAContral CAB S can be used in a range of applications, from pump down to central vacuum systems

Model	Ordering Information			Technical Data	
	Size	Suited Leybold Pumps*	Part No.	Weight [kg]	Dimensions L x W x H [mm]
VAContral CAB S 380-460 V, 50/60 Hz	3 kW	I	10430100V01	20	700 x 500 x 250
	11 kW	II	10430400V01	25	700 x 500 x 250
	22 kW	III	10431200V01	30	800 x 600 x 400
VAContral CAB M 380-460 V, 50/60 Hz	4 x 3 kW	I	10430100V02	30	800 x 600 x 400
	4 x 11 kW	II	10430400V02	40	1200 x 800 x 300
	4 x 22 kW	III	10431200V02	55	1200 x 800 x 300

Maximal permissible ambient temperature: 46 °C

* I < 3 kW: NOVADRY ND 65 -200, CLAWVAC CP 65-150, SOGEVAC SV 65-100B

* II < 11 kW: CLAWVAC CP 300, SOGEVAC SV 220 - 320 - 470B SCREWLINE SP 250

* IV < 22 kW: SOGEVAC SV 570 - 630 -750 B(F), SCREWLINE SP 630

Accessories

Liquid separator, see-through



See-through liquid separator with insert for the collection of large particles

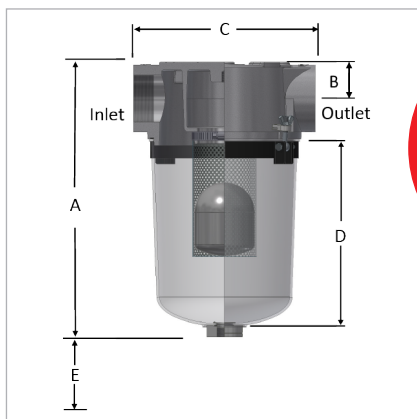

Dimensional drawing of the liquid separators.
For the dimensions please refer to the technical data

**EASY
VISUAL
INSPECTION
AND
CLEANING**

Operating principle

Liquids and larger particles are separated by the integrated baffle and accumulate in a transparent polycarbonate container.

A float ball in the separator rises with the liquid level. At maximum filling level, it interrupts the gas flow on the outlet side to protect the pump.

Technical features

- High impact, shatter resistant, polycarbonate bucket
- Corrosion resistant cast aluminum head with integrated knockout baffle
- Stainless steel float ball for emergency shut off
- 1/2" drain
- 1/4" differential gauge ports 2" to 4"

Customer benefits

- Protects vacuum valves and pumps from particles and deposits
- Quick visual inspection through transparent collection container
- Simple installation, minimal connection costs due to T-shaped design
- Compact filter, space-saving - ideal for tight installation situations

Technical data

		Liquid separator			
		1" 1/4 FP	2" FP	3" FP	4" FP
Inlet / Outlet flange	BSP	G1"1/4	G2"	G3"	G4"
Rated for flow	m ³ /h	68	178	407	424
Dimensions	mm				
A		362	438	522	522
B		38	51	70	70
C		178	229	343	343
D		286	343	378	378
Suggested service height E	mm	229	229	229	229
Holding capacity	l	1.6	3.7	5.7	5.7
Ordering Information	Part No.	95140FP	95144FP	95146FP	95147FP

Dust Filter, see-through



See-through dust filter with insert for the collection of large particles

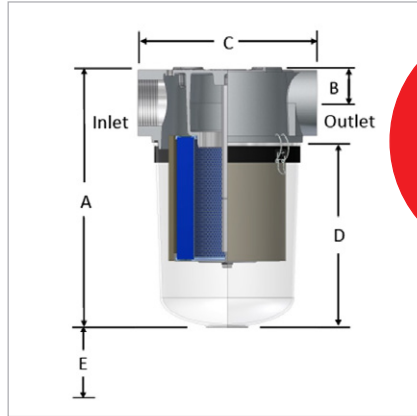

Dimensional drawing of the dust filters. For the dimensions please refer to the technical data

EASY VISUAL INSPECTION AND CLEANING

Operating principle

Inlet vacuum filter with exchangeable polyester cartridge (efficiency on 5 microns particles > 99%)

Technical features

- See-through bucket made from polycarbonate material with high tensile strength for dimensional stability
- Cast, corrosion resistant aluminum top with machined connections with integrated baffle design
- Operating temperature range:
Dust filter: max. 104°C (220°F)
Bucket: max. 125°C (257°F)
- Inlet / Outlet:
G1"1/4 to G4" – depending on the size
G1/4" differential gauge ports

Customer benefits

- Protects vacuum valves and pumps from particles and deposits
- Quick visual inspection through transparent collection container
- Simple installation, minimal connection ycosts due to T-shaped design
- Compact filter, space-saving - ideal for tight installation situations
- Simple cleaning and fast filter insert exchange

Technical data

		Dust filter			
		1" 1/4 FP	2" FP	3" FP	4" FP
Inlet / Outlet flange	BSP	G1"1/4	G2"	G3"	G4"
Rated for flow	m ³ /h	102	298	510	883
Dimensions	mm				
A		334	325	473	473
B		32	51	70	70
C		178	229	343	343
D		257	229	330	330
Suggested service height E	mm	229	229	229	229
Ordering Information:					
Dust filter	Part No.	95354FP	95356FP	95358FP	95360FP
Spare filter cartridge	Part No.	EK95354PC	EK95356PC	EK95358PC	EK95358PC
Replacemen tank (+O-Ring)	Part No.	EK95354TS	EK95356TS	EK95358TS	EK95358TS

Accessories

Dust-filter, standard







Dust filter F 630 and F 200-300

Type		øA	øB	C	D	øE	F	Weight (kg)
F 16-25	mm	G 1/2"	G 1/2"	54	104	100	70	1
F 40	mm	G 1 1/4"	G 1 1/4"	74	115	135	75	1.5
F 65-100	mm	G 1 1/4"	G 1 1/4"	98	172	172	130	2
F 200-300	mm	G 2"	G 2"	118	287	200	230	4.5
F 630	mm	DN 100 PN 10	DN 100 PN 10	220	358	340	250	33

The filters consist of a steel housing and a lid with three quick locking clips.

For use on **SOGEVAC, NOVADRY, CLAWVAC and DRYVAC.**

Our solution

Polyester Filter Cartridge

- Separation of particles down to 5 µm (moist process: dust, powders, chips etc.)

Metal Filter Cartridge

- 0.08 mm (0.003 in.) mesh

Customer benefits

- Same housing for different cartridges
- High separation capacity
- Quickly exchangeable cartridge

Technical Notes

We recommend installing the filters horizontally on a 90° bend. This will prevent separated particles from falling into the intake line when disassembling the filter.

Ordering information

	Dust filter	
	Polyester Filter Cartridge Part No.	Metal Cartridge Part No.
F 16-25 (G 1/2")	711 27 094	711 27 093
Spare cartridge for F 16-25	712 61 288	E 710 65 813
F 40 (G 1 1/4")	711 27 104	711 27 103
Spare cartridge for F 40	712 61 298	710 49 083
F 65-100 (G 1 1/4")	711 27 114	711 27 113
Spare cartridge for F 65-100	712 61 308	E 712 13 324
F 200-300 (G 2")	711 27 124	711 27 123
F 630 (DN 100 PN 10)	711 27 164	711 27 163
Spare cartridge for F 630 (DN 100 PN 10)	712 61 508	E 710 37 734

LF dust filter & liquid separator

NEW



**TRIPLE
PROTECTION**



Type		A	B	C	øD	E	F	G	H
LF550	mm	522	584	261	261	364	124	550	1556 to 1856
LF1800	mm	900	990	450	750	654	219	800	1770 / 1920

Our LF range offers triple protection:

- Liquid separator: holds the liquids that can potentially be sucked in with the pumped gas
- Demister: catches the mists (thin droplets) and converts them to bigger drops of liquid
- Polyester filter: catches all particles over 5µm

Our solution

- Self supported, adjustable feet
- Two sizes available: 550 and 1800 m³/h
- Auto-drain systems available as an option

Customer benefits

- Increases pump lifetime and reliability: less wear and less corrosion inside the pump
- Reduces maintenance costs: on oil-sealed pumps, the oil and the oil demisters will last longer
- Increases uptime: fewer pump stops
- Easy to clean and service:
 - Wide flange on the top
 - Drain valve at the bottom
 - Piping stays connected during cleaning

Technical data

		LF filter & liquid separator		
		LF550	LF1800	Auto-Drain LFP
Pumping speed	m ³ /h	550	1800	-
Inlet / Outlet		DN80	DN150	G³/₄" F (inlet)
Liquid capacity		19 l	40 l	30 l/h

Ordering information

		LF550	LF1800	Auto-Drain LFP
Part No.		177005A27	10441800A01	10440001A01

Vacuum pressure gauges

Vacuum pressure gauges



**EASY
PRESSURE
MONITORING**

Typical Applications

- Food and packaging industry
- Vacuum process quality assurance

Our solution

- Measurement range 1200 to 0.1 mbar
- Usage possible directly in a vacuum
- Data logging via USB interface and internal memory for up to 2000 measured values
- Online measurement via USB possible; measuring data exportable
- Cordless power supply with standard 9 V battery or 15 V DC adapter
- Pressure unit selectable amongst mbar, Torr and Pascal
- Windows software VacuGraph for measuring data storage and PC analysis (optional)

Customer benefits

The temperature compensated handheld gauge PIEZOVAC PV 101 is equipped with an internal piezoresistive silicone sensor and offers gas type independent measurement in the range of 1200 to 0.1 mbar.

The PIEZOVAC PV 101 measurement gauges are universal to use - as a mobile handheld instrument or fixed to a vacuum installation. Operates even under full vacuum conditions.

For example: These gauges can be enclosed to the packaging during the packing process to monitor the real pressure in the inner packaging.

Ordering information

Vacuum pressure gauges

	Part No.
PIEZOVAC PV 101, DN 16 ISO-KF incl. AIMn block battery, 9V 6LR61	230 080 V01
VacuGraph Windows software accessory set, including USB interface cable (2 m), 12V AC adapter (100-260V, 50/60 Hz), protection case	230 082 V01

For detailed information please refer to our General Catalog or contact us.

Oil

LEYBONOL LVO vacuum oil



LEYBONOL food-grade oil

LEYBONOL oils and lubricants from Leybold are especially designed with regard to the high demands in vacuum technology.

Their vapour pressure is low at high temperatures and the water content and water uptake is minimal. Their viscosity characteristics are flat, lubricating properties excellent, and they have high resistance against thermal decomposition and increased mechanical stress.

The food-grade LEYBONOL is registered at NSF (Lev. H1). So it is ideal for use in food processing and packaging areas.

LVO 140 and LVO 150

Mineral oil with additives

- Resistant against oxidation
- Highly resistant to contamination

Product examples:

- LVO 140: SOGEVAC (A-series ≤ SV65, B-series ≤ SV25B)
- LVO 150: SOGEVAC (A-series ≥ SV 100, B-series ≥ SV 40 B)

LVO 300 and LVO 320

Synthetic oil (PAO with additives)

- High thermal and oxidative stability

Product examples:

- SOGEVAC, VACUBE

LVO 400 and LVO 410

Synthetic oil (perfluoropolyether PFPE, free of additives)

- Chemical inert, highest thermal stability; for MAP packaging of red meat with high oxygen concentration

Product examples:

- RUVAC, DRYVAC, SOGEVAC

LVO 700

Synthetic cyclic hydrocarbon

- Very high thermal stability and highly resistant against oxidation and decomposition, long lifetime

Product examples:

- SOGEVAC

Ordering information

	Part No.		Part No.
LEYBONOL LVO 140, 1 liter	L14001	LEYBONOL LVO 400, 1 liter	L40001
LEYBONOL LVO 150, 1 liter	L15001	LEYBONOL LVO 410, 0,6 liter	L41000
LEYBONOL LVO 150, 20 liter	L15020	LEYBONOL LVO 410, 1 liter	L41001
LEYBONOL LVO 300, 1 liter	L30001	LEYBONOL LVO 700, 2 liter	L70002
LEYBONOL LVO 300, 5 liter	L30005	LEYBONOL LVO 700, 5 liter	L70005
LEYBONOL LVO 300, 20 liter	L30020	LEYBONOL LVO 700, 20 liter	L70020
LEYBONOL LVO 320, 20 liter	L32020		

For detailed information please refer to our General Catalog or contact us.

Range of stainless steel fittings

Fittings

- Made of stainless steel 316 or 316L grade for withstanding daily washdown process
- Sealing to be made with PTFE tape or suitable sealing glue
- Allows to connect the vacuum pump inlet to your process



Union coupling

To be mounted at the pump inlet. Allows orientating the pipe / filter in any wished position.

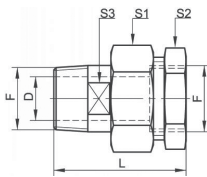
		F	G1/2"	G1"1/4	G2"
		L	50	68	78
		D	15,5	33	48
		S1	32	55	75
		S2	30	52	70
		S3	18	38	54
		Part. No.	UC050SST	UC125SST	UC200SST

Double nipple

To be inserted between the union coupling and the filter (or between the pump and filter directly).

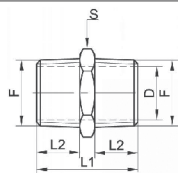
		F	G1/2"	G1"1/4	G2"	G3"	G4"
		L1	34	52.5	62	78.4	94
		D	14	32	50	77	102
		S	22	46	65	90	120
		Part. No.	DN050SST	DN125SST	DN200SST	DN300SST	DN400SST

Double nipple - long version

Same as above. In longer version to move filter away from pump inlet in case of space restriction.

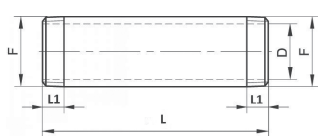
		F	G2"	G3"	G4"
		D	53.3	80.9	106.4
		L	100	200	100
		L1	20	30	35
		Part. No.	DNL200SST	DNL300SST	DNL400SST

Elbow 90°

Always use an elbow when mounting a filter to protect the pump from particles falling in the inlet when cleaning or replacing the filtering cartridge.

		F	G1/2"	G1"1/4	G2"	G3"	G4"
		D	27	49	69	99	125
		L	27.5	45.5	57.5	78.5	96.5
		Part. No.	EL050SST	EL125SST	EL200SST	EL300SST	EL400SST

Hose adapter (hexagonal)

To be used for flexible hose (PVC) connection.

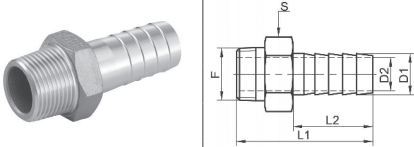
	F	G1/2"	G3/4"	G1"1/4	G1"1/2	G2"
	D1	14	20.5	33	39.5	52
	D2	9	14.5	25.5	32	42.5
	S	24	31	46	52	62
	L1	64	69	81	95	106
	L2	40	40	46	59	65
	Part. No.	HA050SST	HA075SST	HA125SST	HA150SST	HA200SST

Hose adapter (cylindrical)

Same as above for bigger diameters.

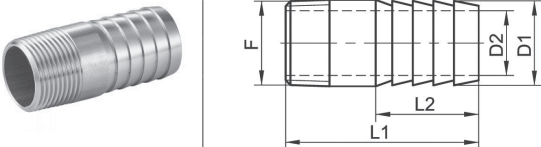
	F	G3"	G4"
	D1	89	114
	D2	80.9	106.3
	L1	120	140
	L2	60	70
	Part. No.	HA300SST	HA400SST

Male - Female reduction

Allows all possible mounting combinations.

	F1	G3/4"	G1"1/2	G2"	G3"
	F2	G1/2"	G1"1/4	G1"1/4	G2"
	S	27	50	65	90
	L1	21	31	33	42
	L2	15	20	22	30
	Part. No.	R075050SST	R150125SST	R200125SST	R300200SST

Female - Male reduction

Allows to mount hose adapter HA150SST (with D1 = 39.5 mm) on G1"1/4 port.

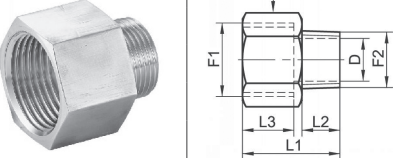
	F1	G1"1/2
	F2	G1"1/4
	S	55
	D	34
	L1	49
	L2	18
	L3	26
	Part. No.	R125150SST

Service – easy, competent, reliable



SERVICE CONTRACTS

Our full range of service contracts are designed to ensure the lowest total cost of ownership of your pumps, maximizing their performance and uptime. From preventive maintenance contracts to warranty extensions, we offer you customized solutions that let you focus fully on your production by providing a perfect match to your needs.



SPARE PARTS AND KITS

Our genuine spare parts fit your vacuum pump perfectly to ensure high reliability, performance, and a long service life. To ease your workflow and ensure you have everything you need for your pump, we put together spare parts kits for specific maintenance activities.



SERVICE TECHNOLOGY CENTER

Fully equipped to handle pumps from every kind of application, even the harshest, our service technology centers are ready to service your pumps. From preventive maintenance to repair, we offer transparent fixed-price solutions and the capability to do anything your pump requires.



FIELD SERVICE

Our team of vacuum pump experts come to your site to perform maintenance on your pumps, whether it is routine service or troubleshooting. Competent, reliable and there for you, they know what your pumps need to perform flawlessly at their best.



CERTIFIED AND EXCHANGE

Our certified and exchange stock is always available in an emergency and to ensure your manufacturing continues as smoothly as possible with a minimum of downtime. All pumps come with a 12-month warranty and are rebuilt and tested to industry standards to ensure that they deliver OEM performance.



LEYBONOL VACUUM PUMP OIL

LEYBONOL has been specially formulated to achieve the best performance for your pump. The premium quality of LEYBONOL ensures long oil exchange intervals and reduces power consumption as well as wear and maintenance costs. Our certified oils keep your production running and extend your pump life expectancy.



GENIUS INSTANT INSIGHTS™

Our connectivity solution offers you 24/7 remote mobile access to your vacuum pumps. Alarms on failures, service maintenance, insights on up-time and energy consumption are all transparent on the Genius Portal. With Genius you can set up real time notifications about important events coming from the vacuum system, giving you the opportunity to avoid costly downtime and production losses – it has never been so convenient and easy to have a healthy and reliable vacuum pump installation.



HEALTH CHECK PRO

Our approach to keep your vacuum pumps always in best shape. With Health Check PRO, we perform regular assessment to the pumps, it consists of non-invasive inspection of parts, connections, damages and vibration measurement, Health Check PRO allows customers to identify early deviations on pumps condition that could lead to major failure and jeopardize production output, moreover, customer will get detailed report with all recommendations needed to act preventively.

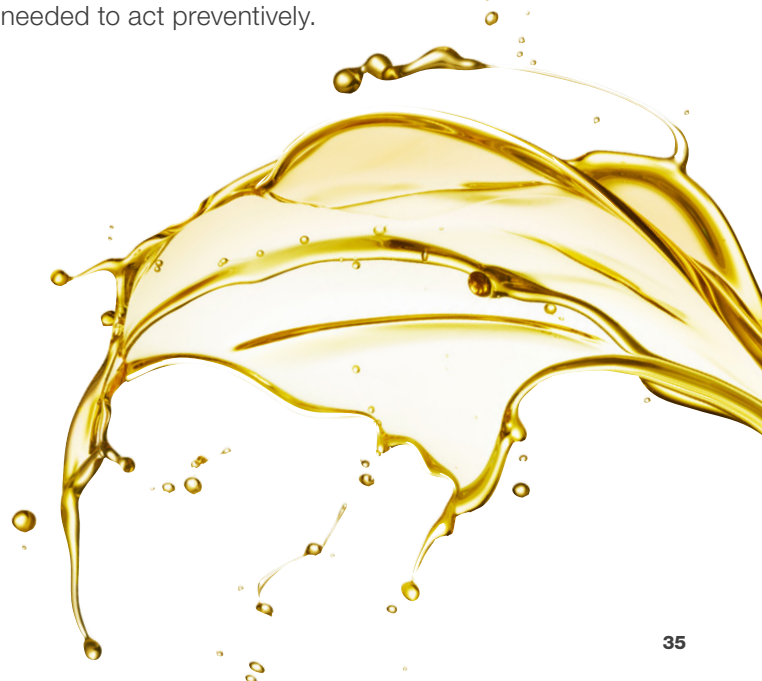

Online shop

leyboldproducts.com

✔ Shop vacuum technology online

✔ Available in more than 12 countries worldwide

Your expectations:

- Easy order process
- Secure payment options
- Large product range, fast delivery

Our solutions:

- Purchase vacuum components which do not require consulting, such as fittings, measuring instruments, pumps, spare parts, vacuum oils, lubricants
- Delivery with invoice, credit card or pre-payment
- Order 24 hours online

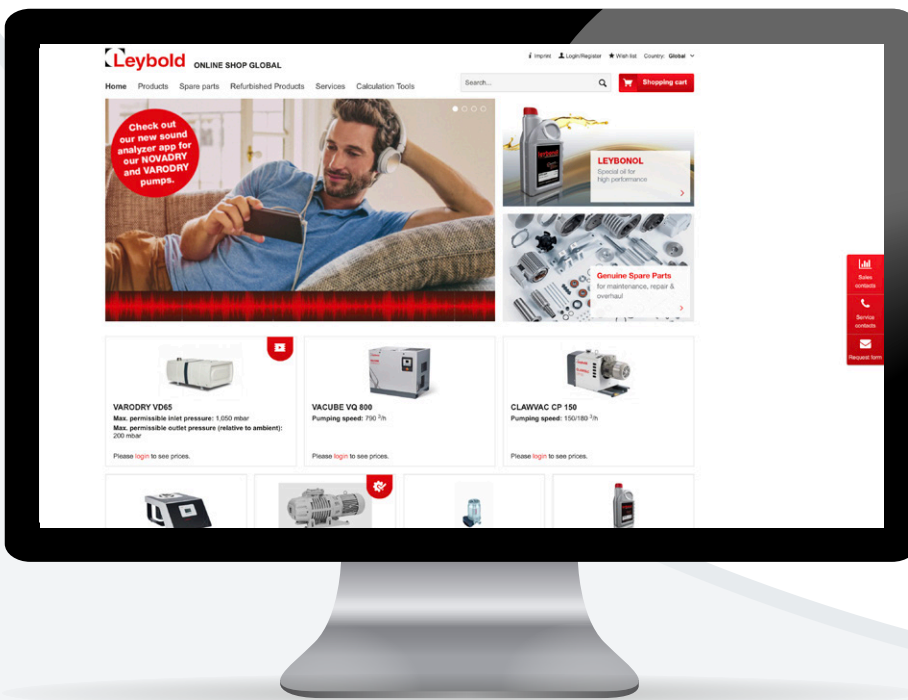

Pioneering products. Passionately applied.